

NO.	PART NO.	NAME	MATERIAL	COLOR	QTY
1	A02-C40DX0000	USB A/F 短体10.6英寸盖文脚1.90(在脚边)	Copper Alloy/SPCC		1PCS
2	A02-A00DX0000	USB A/F 短体10.6英寸芯	PBT		1PCS
3	A02-B20DX0000	USB A/F 90° DIP短端子(2.55英寸)	Copper Alloy		4PCS

REV	DESCRIPTION	DATE
A	试行版 重新修订封面	2011.08.26 2011.09.09

NOTES:

1. MATERIAL SPECIFICATION
  - 1) INSULATION MATERIAL THERMOPLASTIC.
  - 2) SHELL: COPPER ALLOY/SPCC, T: 0.30mm
  - PLATING: NICKEL
  - 3) TERMINAL: COPPER ALLOY, T: 0.25mm
  - PLATING: GOLD/TIN PLATED.
  2. ELECTRICAL CHARACTERISTIC:
    - 1) INSULATION RESISTANCE: 100MΩ MIN.
    - 2) CONTACT RESISTANCE: 30mΩ MAX.
    - 3) WITHSTANDING VOLTAGE: 500V AC.
  3. MECHANICAL CHARACTERISTICS:
    - 1) INSERTION FORCE: 3.57kgf MAX.
    - 2) EXTRACTION FORCE: 1.02kgf MIN.
- ORDERING INFORMATION

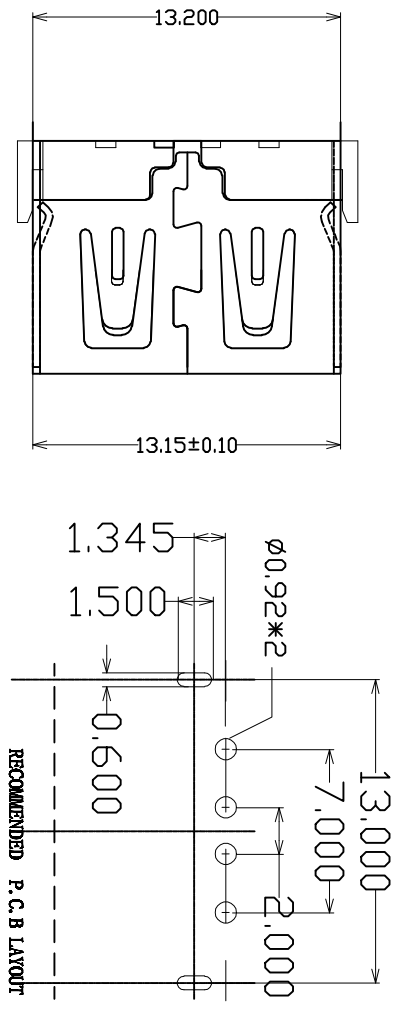
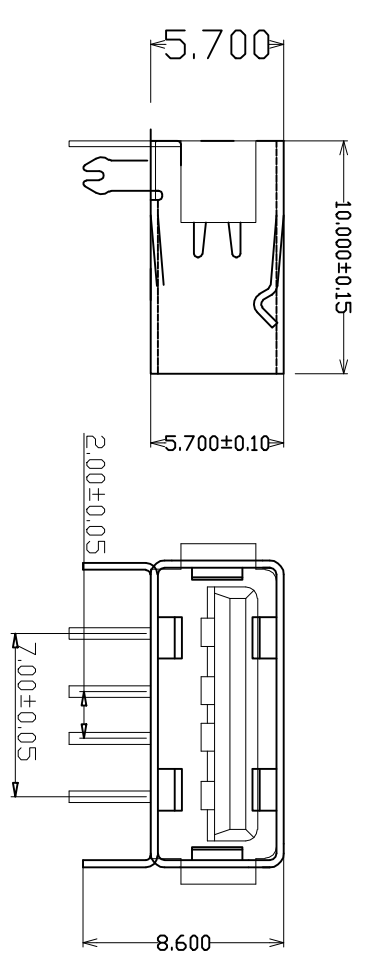

TOLERANCES					
I.	II.	III.	IV.	V.	VI.
A	± 0.20	± 0.10	± 0.05	± 0.03	± 1°
B	± 0.50	± 0.20	± 0.10	± 0.05	± 2°
C	± 0.20	± 0.10	± 0.05	± 0.03	± 1°

MATERIAL: M/M

UNIT: M/M

SCALE: 1:1

THIRD ANGLE

DRAWING BY: SU

CHECK BY: QING

APPROVED: LEE

DATE: 2011.09.09

Brand/Model: USB A/F 90° DIP短体10.6英寸盖文脚(脚边)

PART NAME: Assembly

DRAWING NO. A 02-DXXXXX0X-0063

USER'S OR TOOLING NO. XL001-1B-1