

REV	DATE	DESCRIPTION

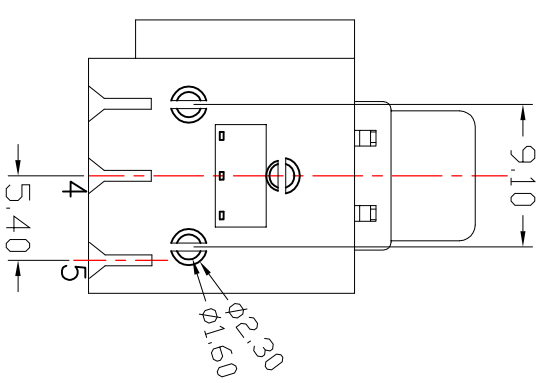

Pin Function:
 1. GND
 2. Vcc
 3. Vin

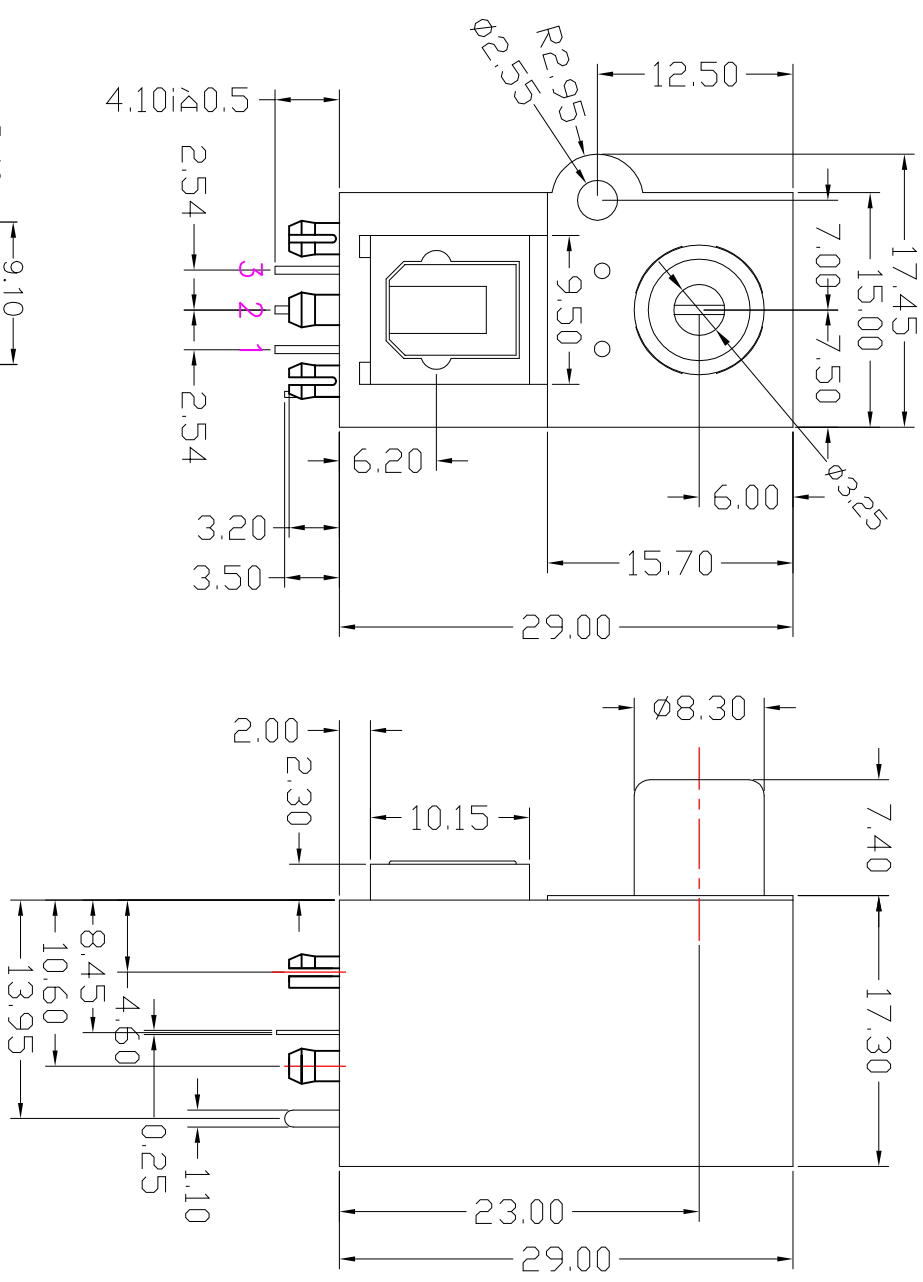
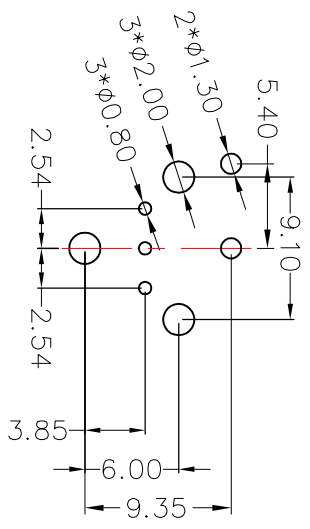

基板參考圖(公差±0.3)
 PCB LAYOUT(Tol.±0.3)

PART NAME	光纤连接器	<h1>XYFWCN</h1>	
PART NUMBER	DLT11R2-D2		
TOLERANCE	±0.20	UNIT	mm
APPROVED		MATERIAL	
CHECK		SCALE	FIT
DRAWING	<i>Snake</i>	DATE	2011/03/01
		PAGE	1/1

Third Angle Projection