

P.C.B LAYOUT

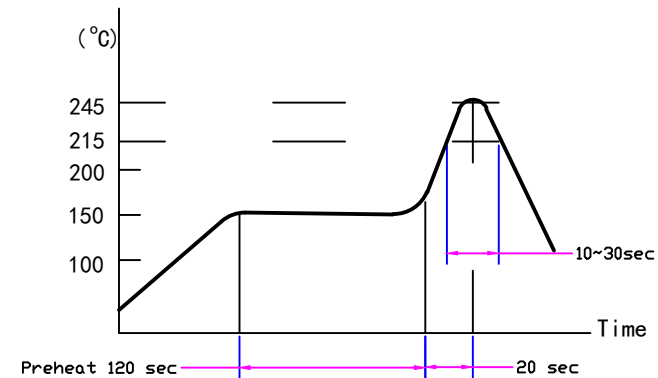

REFLOW SOLDERING CONDITIONS

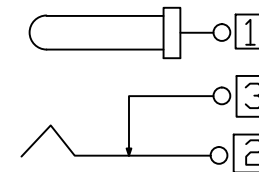
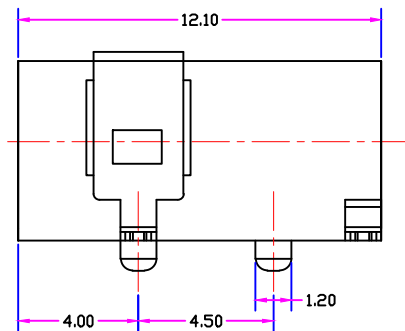
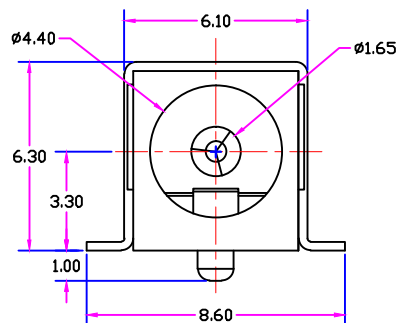

SCHEMATIC

No	DESCRIPTION	QTY	MATERIAL	PLATING	Specifications	DC-011-SMD
1	HOUSING	1	PA6T		Ratings:DC 12V0.5A	TITLE: DC JACK
2	FRAME	1	BRASS	Ag	Contact Resistance: 30m ohm max	UNLESS OTHERWISE SPECIFIED TOLERANCE $\pm 0.1$ ANGLE TOL $\pm 30''$
3	TIP SPRING	1	BRONZE	Ag	Insulation Resistance: 100M ohm at 500V	
4	SHUNT TERMINAL	1	BRASS	Ag	Dielectnic Strength: AC 500V for 1 Minute	UNIT: mm   SCALE: NA
5	PIN	1	BRASS	Ag	Insertion & Extraction Force: 0.3-1.0Kg	DRAWN: CHENG
					Life: 5.000 Cycles	DATE: 2011-12-22
						CHECKED:
						DATE:
						APPROVED:
						DATE:

Shenzhen City Xiangyunfeiwu Technology Co., Ltd.

