

SCHEMATIC

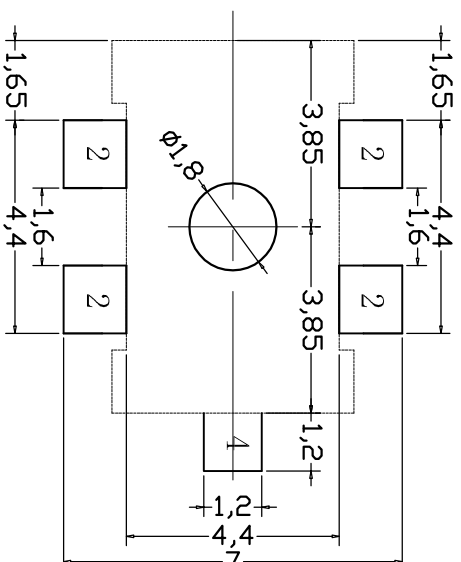
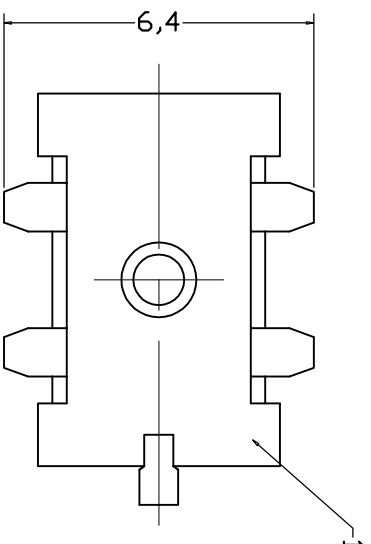
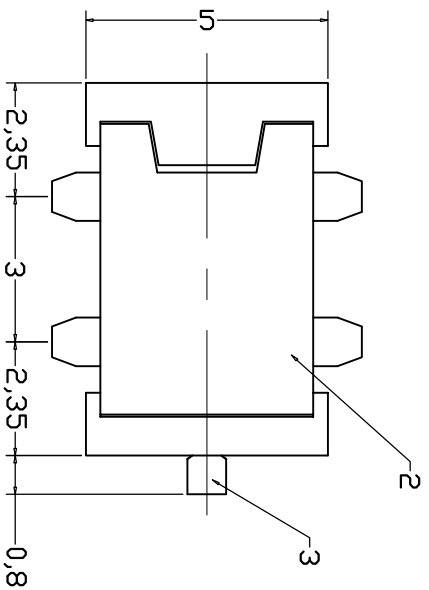

P.C.B. LAND

No	DESCRIPTION	QTY	MATERIAL	PLATING	SPECIFICATIONS
1	HOUSING	1	PA46	UL 94-V0	Rating: 12V DC 0.5A
2	SPRING	1	SUS301	Ag-Plating	Contact resistance: 30 mohms max
3	CURVE PIECE	1	BRASS	Ag-Plating	Insulation resistance: 50 mohms min at 250V DC
					Dielectric withstanding voltage: 250V AC/minute
					Insertion and extraction Force: 3-20N
					Life: 5,000 Cycles

DC-015B-SMD

TITLE: DC JACK

UNLESS OTHERWISE SPECIFIED
TOLERANCE ±0.1
ANGLE TOL ±30°

UNIT: mm SCALE: NA

DRAWN: CHENG

DATE: 2007-06-28

CHECKED:

DATE:

APPROVED:

DATE:

XYFWCN (www.xyfwcn.com)

