

SCHEMATIC

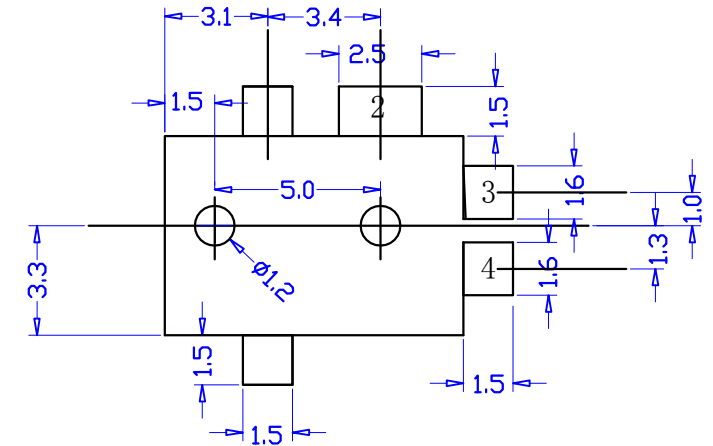
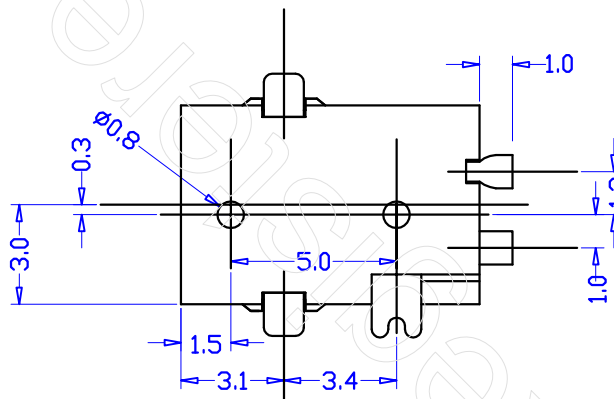
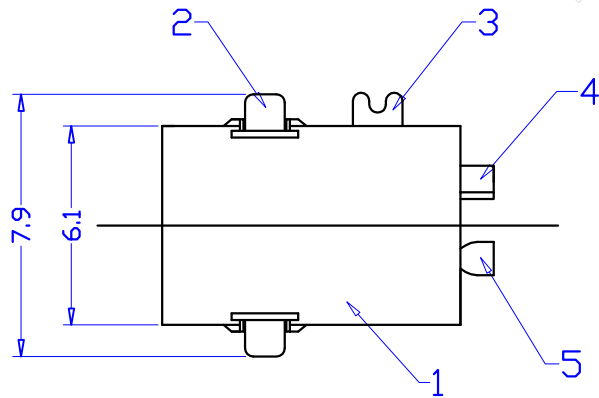

P.C.B LAND

No	DESCRIPTION	QTY	MATERIAL	PLATING	SPECIFICATIONS	DC-012B-SMD
1	HOUSING	1	PA6T	UL 94-V0	Rating:12V DC 0.5A	TITLE: DC JACK
2	CONTACT FOOT	2	BRASS	Ag-Plating	Contact resistance: 30 mohms max	UNLESS OTHERWISE SPECIFIED TOLERANCE ±0.1 ANGLE TOL ±30°
3	SPRING	1	SUS301	Au-Plating	Insulation resistance: 50 mohms min at 250V DC	
4	CURVE PIECE	1	BRASS	Au-Plating	Dielectric withstanding voltage: 250V AC/minute	UNIT: mm SCALE: NA
5	CURVE PIECE	1	BRASS	Ag-Plating	Insertion and extraction Force: 3-20N	DRAWN: CHENG
					Life: 5,000 Cycles	DATE: 2004-04-08
						CHECKED:
						DATE:
						APPROVED:
						DATE:

XYFWCN(www.xyfwcn.com)

