

SCHEMATIC

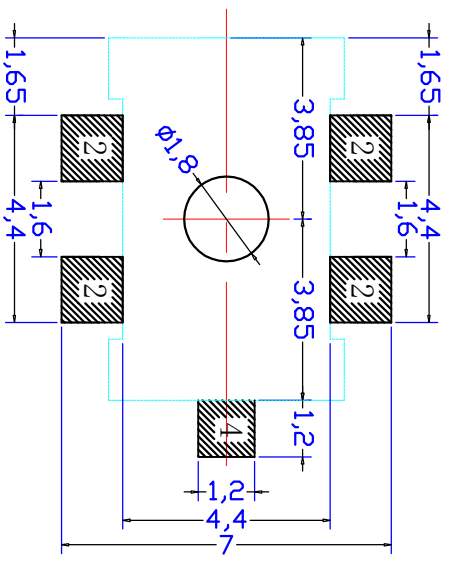

P.C.B LAND

No	DESCRIPTION	QTY	MATERIAL	PLATING	SPECIFICATIONS
1	HOUSING	1	PA46	UL 94-V0	Rating: 12V DC 0.5A
2	SPRING	1	SUS301	Ag-Plating	Contact resistance: 30 mohms max
3	CURVE PLECE	1	BRASS	Ag-Plating	Insulation resistance: 50 mohms min at 250V DC Dielectric withstanding voltage: 250V AC/minute Insertion and extraction Force: 3-20N Life: 5.000 Cycles
					UNIT: mm SCALE: NA DRAWN: CHENG DATE: 2006-06-18 CHECKED: DATE: APPROVED: DATE:
Jian Feng Ele Hard Plastic Ctronic Ware Plastic					TITLE: DC JACK UNLESS OTHERWISE SPECIFIED TOLERANCE $\pm 0.1$ ANGLE TOL $\pm 30^\circ$

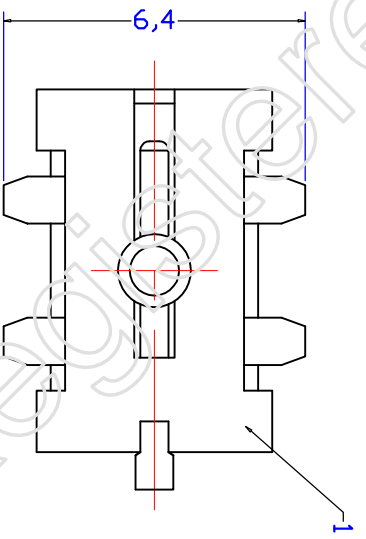
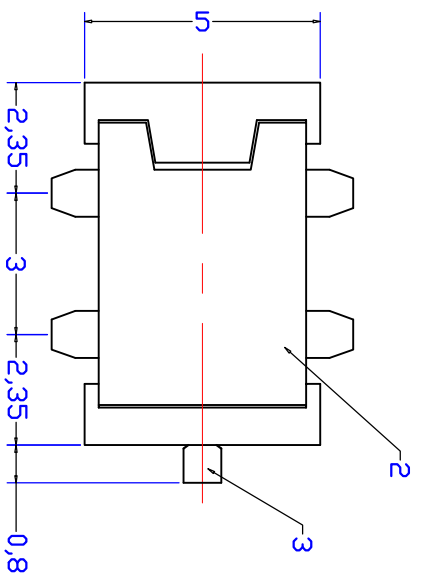